

## Experiment 1C

FV 7/13/06

### ZINC THE BISMARCK

**MATERIALS:** ruler, thirty-three galvanized washers, one red washer, 3 M hydrochloric acid, three 50 mL beakers, 150 mL beaker with graduations.

**PURPOSE:** The purpose of this experiment is to determine how many millimeters of zinc, and layers of zinc atoms, are present on a galvanized steel washer. The volume and density of the washer will also be determined by graphical means, using Excel. This lab is designed to introduce the student to the nature of physical measurements and the importance of accuracy, precision, significant figures, and proper units.

**LEARNING OBJECTIVES:** By the end of this experiment, the student should be able to demonstrate these proficiencies:

1. Identify and use the following equipment: top-loading balance, analytical balance, graduated equipment.
2. Organize data into a table.
3. Describe the differences in the precision of the analytical and top-loading balance.
4. Describe the relationship between experimental measurements, precision and significant figures.
5. Apply the rules for significant figures.
6. Use dimensional analysis for problem solving.
7. Calculate percent error.
8. Create graphs in Excel and use them to determine properties not directly measured.

**PRE-LAB:** Complete the pre-lab questions on p. E1C-8 before lab. Print out this lab experiment and bring it to lab.

**DISCUSSION:** Because construction materials interact with their environment, even an object as simple as a washer must be considered from a chemical point of view. Corrosion, caused by a salt-water environment, contact with dissimilar metals, or stray currents, can lead to device failure, with possible catastrophic results. One form of corrosion protection is to “galvanize” the washer, which means to coat the base material (usually steel) with a thin layer of zinc. The zinc is more reactive than the steel, and thus protects the load-bearing material. Hardware can be galvanized by the “hot-dip” method, where the object is dipped in molten zinc, or by plating the Zn onto the surface electrochemically. This concept of rust protection is carried out on a large scale, on old and modern boats, with zinc plates attached to the iron hull. There’s no sign of the zinc plates remaining on the hull of the sunken Bismarck after decades of corrosion<sup>1</sup>.

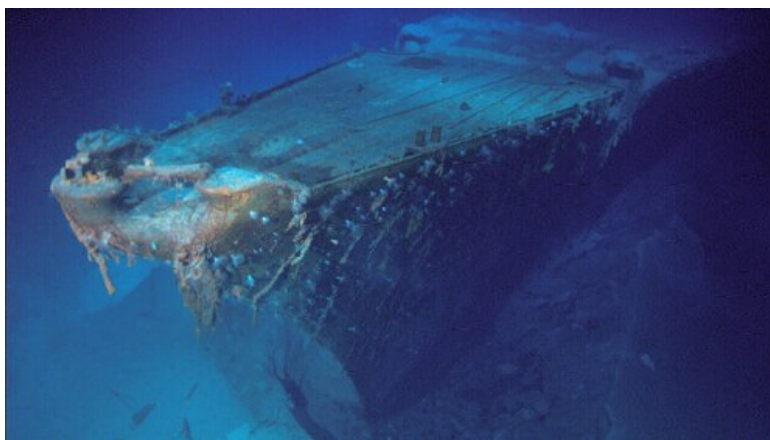

Bow of the sunken Bismarck.<sup>1</sup>

---

<sup>1</sup> For information and pictures of the Bismarck, see <http://www.kbismarck.com/wreck.html> or [http://www.bismarck-class.dk/bismarck/wreck/bismarck\\_wreck\\_1.html](http://www.bismarck-class.dk/bismarck/wreck/bismarck_wreck_1.html).

**SCENARIO:** You work in the quality control lab of Wash-R-Us International, a hardware conglomerate. Your company has a Navy contract for 3/8" galvanized flat washers, which must conform to MILSPEC MS-15795. In addition to specific size characteristics and tolerances, the contract calls for a coating thickness of  $0.055 \pm 0.010$  mm, and an overall density of  $8.3 \pm 0.5$  g/cm<sup>3</sup>. Your task is to evaluate a sample of your company's product, to ensure that they meet these specifications.

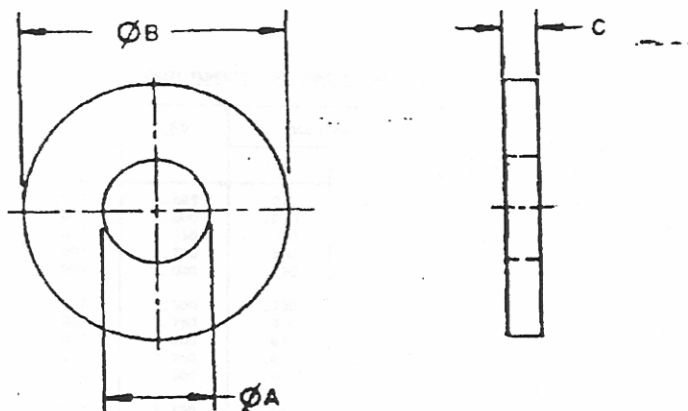

DIS TION SY This is the document document document	F. A.	AR	INTERNATIONAL INTEREST	TITLE	MILITARY STANDARD
	Other Code	AS 99		WASHER, FLAT-METAL, ROUND GENERAL PURPOSE	MS 15795
	PROCUREMENT SPECIFICATION	SUPERSEDES:		PAGE	1 OF 8
	FF-W-92	BEBX SERIES IN PART			
AMSC N/A	DD FORM 672-1 (COORDINATED)	PREVIOUS EDITIONS OF THIS FORM ARE OBSOLETE		5310-1408	

**PROCEDURE:**

Caution: No flames are permitted in the laboratory during this experiment.

The instructor will demonstrate the use of the analytical and top-loading balances.

Midshipmen should work in pairs except for Part C. Start with either Part A or Part B, as directed by your instructor. Do the remaining part when you complete the first segment of the lab. Part C can be done whenever you have a spare minute and the designated balance is free.

**Part A:**

1. Obtain 3 galvanized washers. Measure and record the dimensions of each washer in tabular form on p. E1C-4. Find and record the mass of each washer using the analytical balance. Record a physical description of each washer. Be sure you have a way to tell which washer has which mass as you proceed with the experiment. Have your instructor check your data before proceeding.
2. Obtain 10 mL of 3 M hydrochloric acid in a 50 mL beaker. Working in the fume hood, place one washer in the acid and let it react until the vigorous effervescence stops. Using forceps, carefully remove the washer, rinse with distilled water, and dry. Weigh the dry washer on the analytical balance and record the new mass.
3. Dispose of the reaction mixture by pouring down the drain.
4. Repeat Steps 2 and 3 with your other washers.
5. Dispose of your washers in the beaker labeled waste washers.

**Part B:**

1. Create a data table on page E1C-4 to record water volume, total mass (beaker + water + washers) and number of washers.
2. Place 70-80 mL of water in a 150 mL beaker. Record the actual volume, to the nearest 1 mL, as read from the graduations on the beaker. Weigh the beaker and water on the top-loading balance, and record the value.
3. GENTLY place five (5) unreacted washers into the beaker. Record the new mass and volume.
4. Repeat step 3, adding five washers at a time, and recording total mass and volume readings. Continue until you have added a total of 30 washers. Be careful not to let the water splash out. Try to keep the washers lying flat; washers must be completely immersed for the volume readings to be meaningful.
5. When you have collected all of the data, decant (pour off) the water and sandwich the washers between paper towels, to dry them for the next group.

**Part C:**

1. Your instructor designated a specific (red) washer and a specific analytical balance to use in determining its mass. At any time during the experiment, determine the mass of the washer on the specified balance. EACH midshipman should do this independently. Make sure that the balance reads zero before your measurement. Record your result, and also enter it on the blackboard or in your instructor's summary table. Keep the red washer at the designated balance.

Very useful information from the Pre-Lab:

Density of zinc: \_\_\_\_\_

Atomic radius of a zinc atom: \_\_\_\_\_

Equation for the area of circle: \_\_\_\_\_

Equation for the circumference of a circle: \_\_\_\_\_

Name \_\_\_\_\_

Section \_\_\_\_\_

Partner \_\_\_\_\_

Date \_\_\_\_\_

**DATA SECTION**  
**Experiment 1C**

**Part A:** Measure and record (in tabular form) the dimensions and mass of each washer. Make sure that you have all three dimensions specified in the mechanical drawing. (The symbol  $\emptyset$  stands for diameter.) Record a physical description of each washer. Have your instructor check your data before proceeding. Use the correct number of significant figures for each instrument. Label the units for each measurement. Label each row and column of data appropriately.

Instructor's initials: \_\_\_\_\_

**Part B:** Measure and record (in tabular form) the volume reading, mass reading, and number of washers immersed, as directed in the procedure. Use the correct number of significant figures for each device. Label the units for each measurement. Label each row and column of data appropriately. Have your instructor check your data before proceeding.

Instructor's initials: \_\_\_\_\_

**Part C:** Measure and record the mass of the red washer on the specified analytical balance. Be sure that the balance reads zero before making your measurement. EACH midshipman should record his or her own value, and also enter it into the instructor's summary table.

mass of red washer, partner 1 \_\_\_\_\_

partner 2 \_\_\_\_\_

**DATA TREATMENT**  
**Experiment 1C**

**Part A:**

1. Using the experimental measurements for your first washer and information from the pre-lab, calculate:

(a) the total surface area in square millimeters.

(b) the volume of the zinc coating in cubic millimeters.

(c) the thickness of the zinc coating in millimeters.

(d) the thickness of the zinc coating in layers of atoms – assume the zinc atoms are arranged one on top of the other as shown to the right.

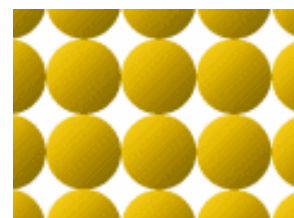

(e) the actual number of layers in the zinc coating – Zinc atoms are actually arranged in a lattice called “hexagonal closest packed” (like oranges stacked at the grocery store). To correct for this more compact arrangement, simply multiply your answer from part (d) by 1.25.

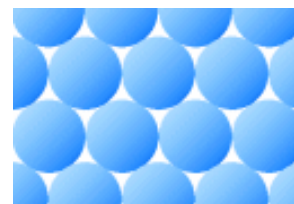

2. Repeat the calculations in Question 1 for your other two washers and summarize the results for all three washers in a table below. Use the correct number of significant figures and units for each entry. Label each row and column of data appropriately.

3. Do the washers conform to the contract specification of Zn layer thickness identified in the Scenario? Explain.

### Part B:

Analysis of Part B requires the use of Excel spreadsheet software. Your instructor may direct you to complete and submit these results at a later date. Follow the directions of YOUR instructor. A self-paced Excel tutorial is available at: [http://www.chemistry.usna.edu/plebeChem/excel\\_tutor/index.htm](http://www.chemistry.usna.edu/plebeChem/excel_tutor/index.htm).

1. From a blank Excel worksheet, create a spreadsheet table showing the number of washers, the mass readings and the volume readings obtained in Part B. Label the columns appropriately, including units as necessary. The number of decimal places displayed should be consistent with the number of significant figures appropriate for the measurement.

2. Create a plot of Volume Reading vs. Number of Washers (y vs. x). Plot a Trendline on the chart. Show both the trendline equation and  $R^2$  value on the chart. Based on the trendline, what is the average volume of a single washer? Think about how many significant figures are appropriate, based on the data, and report your results in that manner.

Average Volume of one washer: \_\_\_\_\_

3. Create a plot of Mass Reading vs. Volume Reading. Plot a Trendline on the chart. Show both the trendline equation and  $R^2$  value on the chart. Based on the trendline, what is the average density of a single washer? Think about how many significant figures are appropriate, based on the data, and report your results in that manner.

Average Density of one washer: \_\_\_\_\_

4. Do the washers conform to the contract specification of density identified in the Scenario? Explain.

### Part C:

1. Based on the data from the entire class, what is the mass of the red washer? What is the maximum uncertainty in the measurement? Report the measured mass of the washer, with uncertainty:

\_\_\_\_\_  $\pm$  \_\_\_\_\_ g

**QUESTIONS FOR CONSIDERATION**  
**Experiment 1C**

1. Would these mistakes cause the calculated thickness of the zinc coating to be higher, lower, or the same as the actual thickness? Briefly explain.

- (a) You used 20 mL of 3 M hydrochloric acid instead of 10 mL.
- (b) You removed the washer from the hydrochloric acid before the reaction stopped effervescing.
- (c) You left the washer in the hydrochloric acid for 30 minutes.
- (d) You did not completely dry your washer before taking its mass.

2. The zinc coating is applied to iron or steel objects by electroplating. In this process the item to be galvanized is suspended from an electrode in a container of zinc chloride. An electric current is passed through the system, causing zinc atoms to bond to the surface of the object. The longer the electricity is applied, the thicker the zinc coating.

The electroplating process used by a local company is designed to galvanize 200 washers per batch with each washer having an average of 0.35 g of zinc coating. If it uses an electrical current of 175 amperes, how many hours will it take to produce 250,000 washers?

Useful information:

- 1 ampere current = 1 coulomb charge/second
- 1 mol electrons = 96,500 coulombs of charge
- 2 mol electrons = 1 mol Zn

3. With digital instruments it is understood that an uncertainty of at least one unit exists in the last digit of the measured quantity.

- (a) Calculate your percent error in the mass of the zinc layer if the measurement is 0.0001 g too high.
- (b) If you had used the top-loading balance (which measures to  $\pm 0.01$  g), would the percent error be larger, smaller, or the same? Explain your reasoning.

4. A 10.0 lb sacrificial zinc anode is attached to a ship's hull. The role of this anode is to protect the steel hull of the ship from corrosion by undergoing the following reaction:  $\text{Zn (s)} \rightarrow \text{Zn}^{2+} \text{ (aq)} + 2\text{e}^-$ . As this reaction proceeds, the anode is gradually consumed, as the solid zinc is converted to  $\text{Zn}^{2+}$  ions.

- (a) Calculate the number of atoms of zinc in a 10.0 lb anode.
- (b) The manufacturer's brochure states that this anode will last at least 456 days. From this information, calculate how many reactions must occur each minute for the anode to be consumed in 456 days.

5. From the data in Part B, you can determine the average mass of a single washer. How does this compare with the average washer mass determined in Part A? Which is more precise? Explain your answer. What, if anything, can you say about the accuracy of these determinations?

6. It is NOT likely that every measurement of the red washer was the same, even though everyone measured the same object on the same balance. Why do the values differ?

Name \_\_\_\_\_

Section \_\_\_\_\_

Date \_\_\_\_\_

**PRE-LAB QUESTIONS**  
**Experiment 1C**

**Complete these questions prior to attending lab. They will be collected before you can start the experiment.**

1. What does the term "galvanized" mean? Why would galvanizing a steel washer be useful?
  
2. In the laboratory you will remove the zinc from the galvanized washer by reacting it with hydrochloric acid to form hydrogen gas and zinc chloride in solution. Write a balanced chemical equation for the reaction. Indicate the physical state of each reactant and product, using the abbreviations: (aq) for aqueous solution, (s) for solid, (l) for liquid, and (g) for gas.
  
3. The safety caution in the procedure section states no flames are allowed in the laboratory during this experiment. Which reactants and/or products warrant this precaution? Briefly explain.
  
4. In addition to your laboratory measurements, you will need to know the density of zinc and atomic radius of a zinc atom. Find this information about zinc in a chemistry handbook or a website. Record the density and atomic radius below AND on page E1C-3 of this lab. Cite the sources of this information by listing the author or editor, book title, publisher, city of publication, publication date, and page number, for references in print, or the URL and date accessed, for those on the internet.

Density of zinc: \_\_\_\_\_

Atomic radius of a zinc atom: \_\_\_\_\_

Citation:

5. What are the equations for calculating the area of circle and the circumference of a circle? Record these equations below AND on page E1C-3 of this lab.

6. You may be using a ruler to measure the dimensions of your washers. When reading any analog scale you should estimate one additional decimal place than is marked on the scale. Keeping this in mind, what is the length of this paper clip in centimeters? How many significant figures are in your answer? Circle the "uncertain" digit.

Length \_\_\_\_\_

# of Sig Figs \_\_\_\_\_

