

A Practical Exercise

Name: \_\_\_\_\_

Section: \_\_\_\_\_

**I. Purpose.**

1. Introduce Lab Bench equipment.
2. Introduce how to set DC voltage outputs on the Dual DC Power Supply
3. Introduce how to measure the Dual DC Power Supply outputs with the Digital Multimeter

**II. Equipment.**

**Agilent 34401A** Digital Multimeter (DMM)  
**Agilent E3620A** Dual DC Power Supply  
Quad Board and Test Leads

**III. Preparation.**

Receive laboratory safety brief.

**IV. Lab Procedure.**

You must **read** and complete each step.

**Step One:** Introduction to Lab Bench:

- Begin by locating the quick reference card that is located on top of each bench.
- Using this card as a guide, locate the Dual DC Power Supply.
- Locate one of the two Digital Multimeters (DMM).
- Locate the power switch on the right side of the bench, this is labeled “120 V. OUTLETS” and turn on the lab bench with the switch directly below.
- Locate the Quad Board (Figure 1). The Quad Board will be used to construct circuits throughout the semester. Each of the 4 jacks on each “quad” are the same point electrically. You will use the connections to plug in circuit elements, the voltage source, the DMM and other devices in later practical exercises.

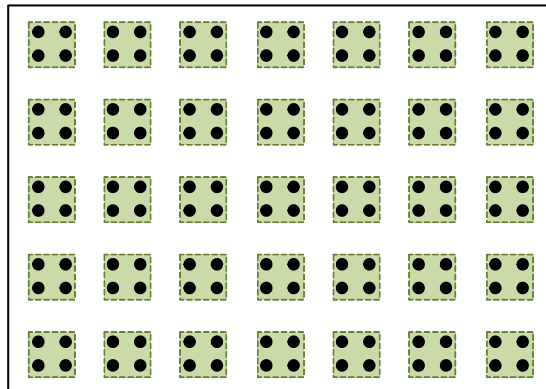

Figure 1: Quad Board

# Introduction to the Laboratory Bench

## A Practical Exercise

- If two meters were plugged into the same two “quads” (Figure 2), would they get the same readings?

Yes                      No

Justify your answer

---

---

---

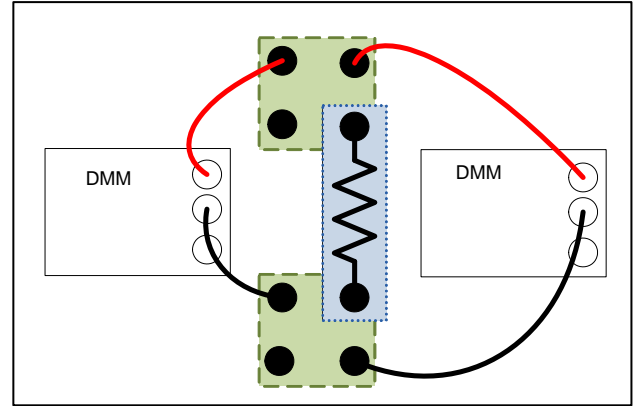

Figure 2

### Step Two: DC Voltage Source:

- We will now investigate the Dual DC Power Supply. This device supplies a DC voltage. Ensure that no wires are connected to the power supply and turn the power supply on.
- There are two buttons on the front which are used to select which Dual DC Power Supply voltage that you wish to display. Each of the voltages, V1 and V2, are adjusted using the “voltage adjust” knobs. Locate these knobs and the display.
- Adjust the left power supply knob, V1, to 20 volts.
- Adjust the right power supply knob, V2, to 10 volts.
- Locate the two “OVERLOAD V1 V2” yellow warning lights next to the display. If the power supply is shorted out (by directly connecting the “+” side to the “-” side, the yellow warning light will turn on.



**CAUTION:**  
**IF YOU GET A YELLOW OVERLOAD LIGHT, IT MANS THAT YOU HAVE MISWIRED YOUR CIRCUIT. YOU MUST IMMEDIATELY TURN OFF THE DUAL POWER SUPPLY WHEN THIS HAPPENS.**

### Step Three: Digital Multimeter (DMM):

We will use the DMM to verify that you have properly set the voltages, V1 and V2, at the desired level. Remember that voltage is a potential difference between two points. You will use the leads from the DMM and connect across the device that you wish to measure - in this case the Dual DC Power Supply outputs, V1 and V2.

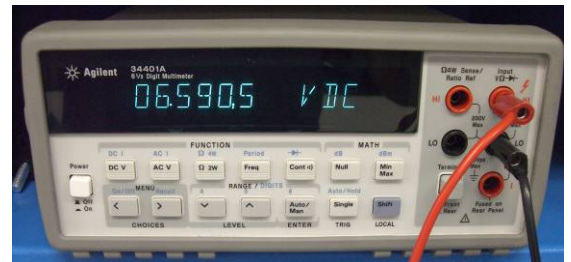

- Turn on the DMM and select the “DC V” function on the DMM.

# Introduction to the Laboratory Bench

## A Practical Exercise

- Turn off the Dual DC Power Supply. The values you set in Step 2 will be remembered, but it is always safer to turn off the voltage source whenever you are connecting cables to your circuit.
- Connect a RED lead from the “+” side of the Dual DC Power Supply for V1 (left side) to the “Input HI” input on the DMM. (Refer to the Quick Reference guide)
- Connect a BLACK lead from the “-“ side of the Dual DC Power Supply for V1 to the “Input LO” input on the DMM. (Refer to the Quick Reference guide)
- Turn on the Dual DC Power Supply.
- Record the DMM reading:** \_\_\_\_\_
- Using the voltage adjust knobs on the Dual DC Power Supply, adjust the power supply so that the DMM reads exactly 20V.

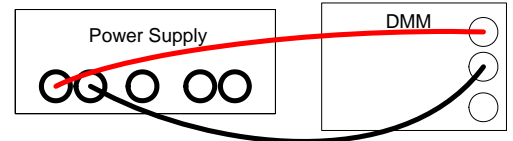

Figure 3

### NOTE:

**YOU SHOULD ALWAYS USE A DMM WHEN ADJUSTING THE SETTINGS ON THE POWER SUPPLY. THE DMM PROVIDES A MORE ACCURATE READING THEN THE POWER SUPPLY'S METER.**

- Turn off the Dual DC Power Supply.
- Swap the red / black banana plugs at the DMM.
- Turn on the Dual DC Power Supply.
- Record the DMM reading:** \_\_\_\_\_
- Does the 2<sup>nd</sup> DMM reading match the first? \_\_\_\_\_

Why Not? \_\_\_\_\_

- Repeat this process for V2 and verify that you correctly set the voltage level to 10 Volts.

Questions:

1) What does the display on the front of the Dual DC Power Supply display? \_\_\_\_\_

2) Can it display the value for V1 and V2 at the same time? \_\_\_\_\_

3) What should you do if one of the Dual Power Supply's yellow "OVERLOAD" lights turns on? \_\_\_\_\_