

A Practical Exercise

Name: _____

Section: _____

I. Purpose.

1. Introduce the Hampden DC machine
2. Introduce the Hampden laboratory bench electrical power supplies
3. Introduce basic permanent magnetic DC motor principles of operation

II. Equipment.

Agilent 34401A Digital Multimeter (DMM)
Agilent E3620A Dual DC Power Supply
Hampden DC Machine

III. Preparation.

Receive the safety brief.

IV. Lab Procedure.

You must **read** and complete each step.

Step One: Safety Quiz.

Complete the following quiz.

1. (**True / False**) The voltages and currents that we will use in this week's DC motor practical exercises and in future AC generator/three-phase power practical exercises can cause death.
2. (**True / False**) While the power is on you can change the circuits as long as you are careful.
3. (**True / False**) The instructor or laboratory technician must check every circuit before it is energized.
4. Electrical shock may occur in which of the following ways?
 - a. When a person comes in contact with both wires of an electric circuit.
 - b. When a person comes in contact with one wire of an energized circuit and the ground.
 - c. When a person comes in contact with the circuit ground and with a metallic part that has become "hot" by being in contact with an energized wire.
 - d. All the above.
5. The severity of a shock received when a person becomes a part of an electrical circuit is determined by what primary factor?

A Practical Exercise

- a. The rate of flow of current through the body, measured in amperes.
 - b. The path of the current through the body.
 - c. The length of time the body is in the circuit.
 - d. All the above and other factors which may affect the degree of shock are: the frequency of current phase of the heart cycle when shocks occurs, and the physical and psychological condition of the person.
6. If you think that electrical or mechanical operation is abnormal what should you do?
-

7. (True / False) It is OK to move the machine around if the leads that you are using are too short.
8. (True / False) A convenient way to create a longer lead if you need it is to make a chain of several leads.
9. Which leads should be used to wire the power supply? _____
10. If the power is off, is the one hand rule necessary? _____

Step Two: Create a “permanent” magnet field.

The Hampden DC machine uses an electromagnet not a permanent magnet in its stator to create a magnetic field across its rotor. In this practical exercise we will create a “permanent” magnetic field by applying DC voltage from the laboratory bench excitation supply (Figure 1) across the stator’s field windings (Figure 1).

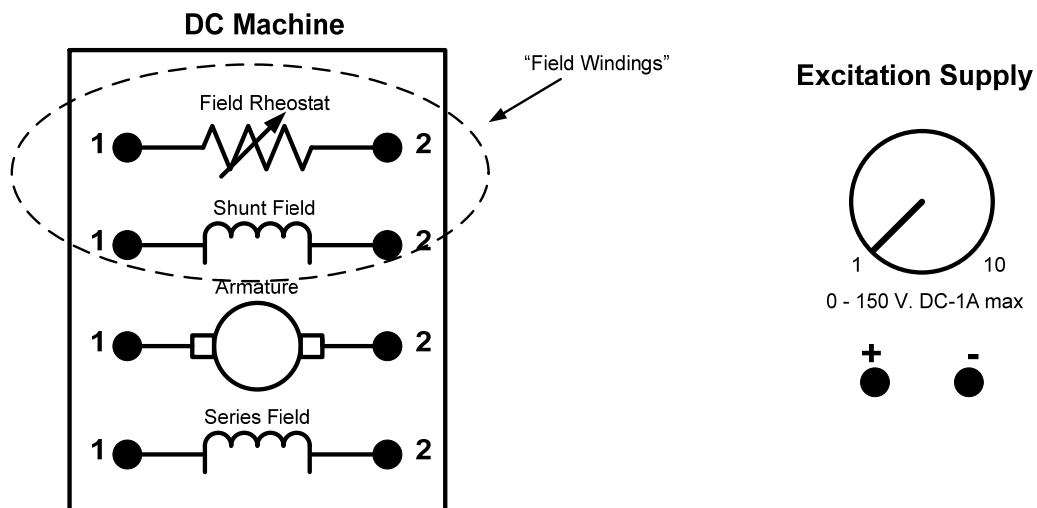

Figure 1

A Practical Exercise

- Using the blue wire connect the Field Rheostat and the Shunt Field in series (Figure 2).
- Using the yellow wires connect the excitation supply to the “Field Windings” (Figure 2).

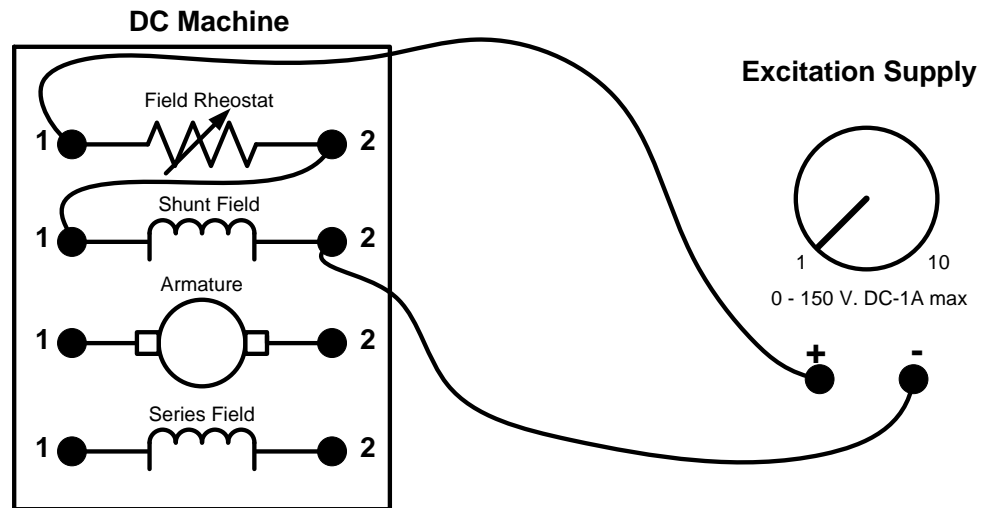

Figure 2

- Turn the field rheostat knob that is located near the top of the DC Machine input panel to the full counter-clockwise position.
- Set the DC voltage to the field windings by rotating the Excitation Supply knob to the number “2” position.

Step Three: Induced voltage

In this step we will demonstrate Faraday’s law by activating the electromagnet in the DC motor’s stator and then rotate by hand the DC machine’s armature loops across the magnetic field. We will observe the induced voltage by connecting the DC motor’s armature loops to the Hampden analog DC volt meter that is located on top of your laboratory bench.

- Using the red and black wires, connect the DC machine’s armature to the Hampden analog DC voltmeter and set the scale for 75 volts (Figure 3).

A Practical Exercise

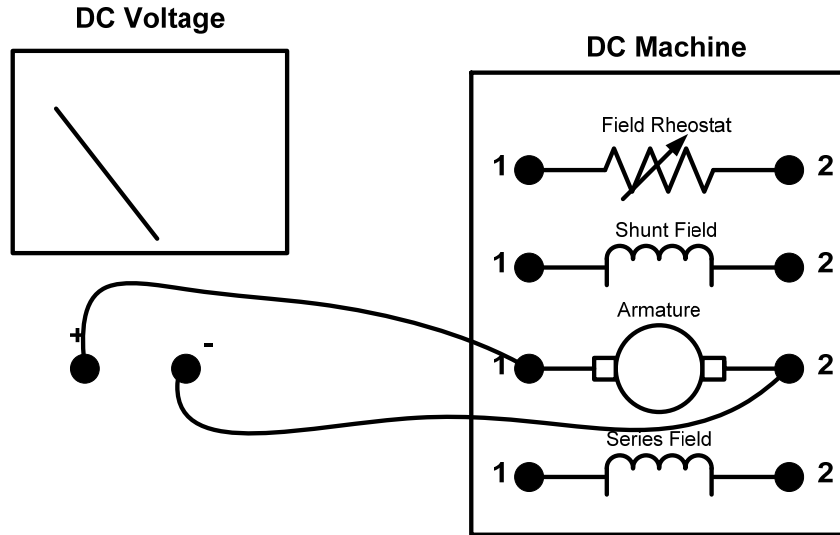

Figure 3

- Ask your instructor or laboratory assistant to check your circuit and then unlock your laboratory bench so you can energize the DC motor.
- Energize your laboratory bench by switching ON the MAIN AC power switch located on the panel to your right.
- Energize your electromagnetic by switching ON the EXCITATION SUPPLY power switch located on the panel to your right.
- With your hand rotate the DC motor shaft counter-clockwise. You will need to remove the blue guard surrounding the motor shaft.

What did you observe? _____

- Again rotate the DC motor shaft counter-clockwise, but this time faster.

What did you observe? _____

- Now rotate the DC motor shaft clockwise.

What did you observe? _____

A Practical Exercise

As you rotated the shaft clockwise/counter-clockwise, what do you observe on the voltmeter display?

Is there a relationship between the polarity of the induced voltage and the direction of rotation?

Explain? _____

Step Four: Introduction to DC motor operations

- Turn OFF the EXCITATION SUPPLY power switch.**
- Turn OFF the MAIN AC power switch.**
- Disconnect the analog DC volt meter.**

We will create a DC motor by applying DC voltage across the armature loop of the Hampden DC machine. This applied current in the armature loop will pass through the magnetic field causing the rotor to spin. We will measure the current going through the armature loop using a Hampden analog DC ammeter.

- Refer to Figure 4 as a guide. Using the yellow wires connect the DC variable output (located beneath the Voltage Adjust knob) via the Hampden analog DC ammeter (located on the top of the workbench) to the Hampden DC machine's armature as shown below.

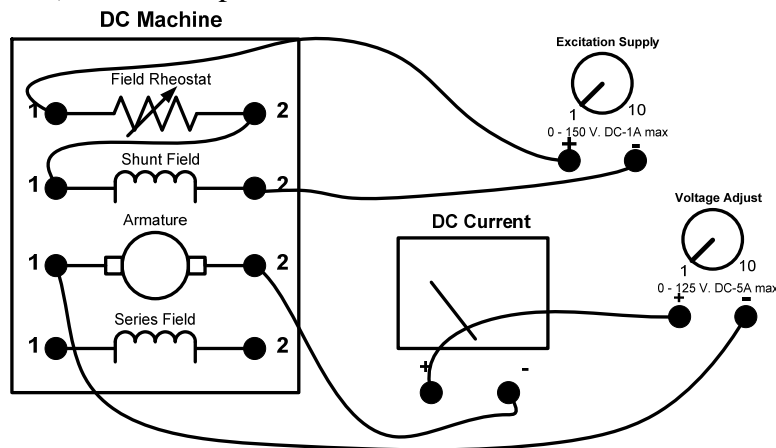

Figure 4

- Ensure that your voltage adjust knob and the excitation supply are rotated to the full counter-clockwise position.**
- Ask your instructor or laboratory assistant to check your circuit.

A Practical Exercise

- Turn ON the MAIN AC power supply switch.
- Turn ON the EXCITATION SUPPLY power switch.
- Set the analog ammeter on the top of the workbench to the 5 Amp setting.
- Energize the magnetic field by rotating the EXCITATION SUPPLY knob clockwise to the “2” position.
- Turn ON the VARIABLE OUTPUT power switch, which enables the VOLTAGE ADJUST knob.
- While slowly rotating the VOLTAGE ADJUST knob clockwise to the “2” position, make the following observation.

What direction does the DC motor’s shaft rotate? _____

- While slowly rotating the VOLTAGE ADJUST knob clockwise to the “4” position, carefully observe the ammeter.

While increasing the voltage did the current through the armature increase or decrease? _____

When you stopped increasing the VOLTAGE ADJUST knob, did the current through the armature increase or decrease? _____

Why would the current decrease after you stop increasing the VOLTAGE ADJUST knob?

To avoid runaways ensure that you power down the DC motor in the following sequence.

- Rotate the VOLTAGE ADJUST knob to the full counter-clockwise position (“0”).
- Turn OFF the VARIABLE OUTPUT power switch.
- Rotate the EXCITATION SUPPLY knob to the full counter-clockwise position (“0”).
- Turn OFF the EXCITATION SUPPLY power switch.
- Turn OFF the MAIN AC power switch.

A Practical Exercise

If you switch the polarity of the voltage supply to the armature, would the DC motor rotate in the opposite or same direction? _____

Why? _____

- Reverse the polarity on the armature by swapping the yellow wires that are connected to armature. See Figure 5.

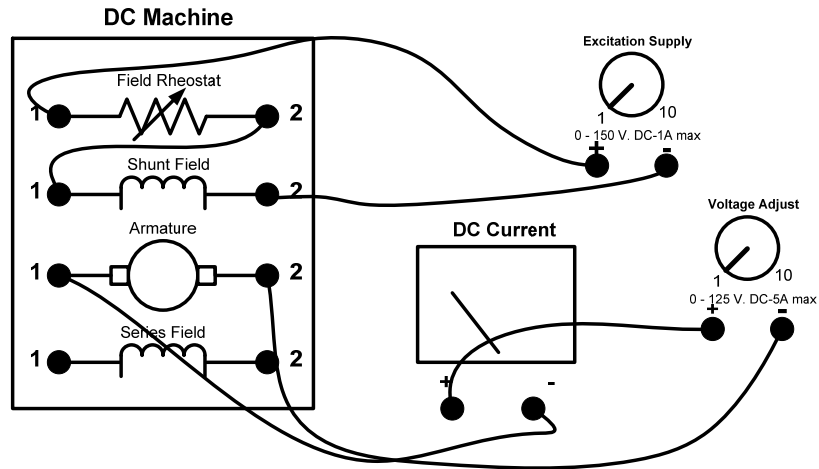

Figure 5.

- Ensure that your voltage adjust knob and the excitation supply are rotated to the full counter-clockwise position.**
- Ask your instructor or laboratory assistant to check your circuit.
- Turn ON the MAIN AC power supply switch.
- Turn ON the EXCITATION SUPPLY power switch.
- Energize the magnetic field by rotating the EXCITATION SUPPLY knob clockwise to the “2” position.
- Turn ON the VARIABLE OUTPUT power switch.
- While slowly rotating the VOLTAGE ADJUST knob clockwise to the “2” position, make the following observation.

Did the DC motor rotate in the same or opposite direction? _____

To avoid runaways ensure that you power down the DC motor in the following sequence.

A Practical Exercise

- Rotate the VOLTAGE ADJUST knob to the full counter-clockwise position (“0”).
- Turn OFF the VOLTAGE ADJUST power switch.
- Rotate the EXCITATION ADJUST knob to the full counter-clockwise position (“0”).
- Turn OFF the EXCITATION SUPPLY power switch.
- Turn OFF the MAIN AC power switch.