

Lecture 28-30: Optimal Digital Receiver Design

Digital Baseband Reception

Conceptually, digital reception is easy. We look at our waveform, and based on our signaling scheme, determine if we've received a 1 or a 0. For Example, NRZ coding, if I see a +V Volts, I know I have a "1", if I see a -V Volts, I know I have a "0".

I have two problems, though: Noise and Distortion.

Noise is going to hide/disguise my signal. Distortion is going to either amplify it or reduce it to some range that does not fall between (+V/-V).

How can I overcome these limitations? Thresholding is a possibility, but how can I account for noise that pushes me over a limit? I need to somehow compare my received noisy, distorted waveform shape to an ideal waveform shape and apply the "what is more likely" test → does it look more like a "1" or a "0".

3 Types of Receiver Architectures

Maximum Likelihood: Based on an observation, pick the most likely result. Assumes no prior knowledge about the signal.

→ Based on your grade on Exam 2, I can predict your grade for the course.

Maximum A Priori: Make an observation, and then weight that observation by the probability of the signal(s) being transmitted.

→ Wednesday is Burger Day in King Hall 90% of the time. You wake up and observe that today is Wednesday, but the menu is garbled. What would you predict would be on the menu?

Maximum A Posteriori: Make an observation, and then weight that observation the cost of making an error. No assumption on prior probabilities.

→ Long range ballistic missile radar. Consider whether the blip is a real target or just noise.

*** In an environment with high SNR, these receivers all perform the same.

The Digital Receiver Problem Statement

We transmit a binary signal $s(t) \in \{s_0(t), s_1(t)\}$, where $s(t)$ is nonzero only on $[0, T_b]$ (i.e., it's only defined for the bit time, a 0 or a 1).

Let the two signals be transmitted with probability: $p_0 = \Pr[s_0(t)]$, $p_1 = \Pr[s_1(t)]$

The received signal is corrupted by noise: $r(t) = s(t) + n(t)$

For a binary communication system, the Probability of Bit Error is given by:

$$P(e) = \Pr[\hat{s} \neq s] = \Pr[\hat{s} \neq s_0 | s = s_0] + \Pr[\hat{s} \neq s_1 | s = s_1]$$

Where $\Pr[\hat{s} \neq s_0 | s = s_0]$ is the conditional probability of the receiver not deciding on s_i given that s_i was transmitted.

To solve for that:

$$\Pr[\hat{s} \neq s_0 | s = s_0] = 1 - \int_{R_0} p(\mathbf{r} | s_0) d\mathbf{r}$$

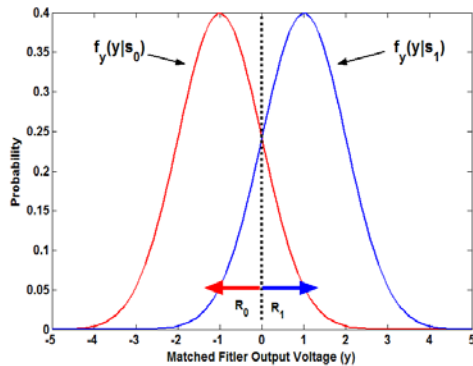

$$\Pr[\hat{s} \neq s_0 | s = s_0] = 1 - \int_{-\infty}^0 \frac{1}{\sqrt{\pi N_0}} \exp\left(-\frac{(r+V)^2}{N_0}\right) dr$$

My Objective

Given $r(t)$, the receiver forms an estimate $\hat{s}(t)$ of the signal $s(t)$ with the goal of minimizing the error probability: $P_e = \Pr[\hat{s}(t) \neq s(t)]$

The Maximum Likelihood Receiver (i.e., a simple Threshold Receiver)

Consider first a **non-Matched Filter** detector (i.e., just a threshold detector). The signaling scheme is baseband data transmission that uses bipolar line codes (+V for a binary 1 and -V for a binary 0) and NRZ Signaling.

The Maximum Likelihood receiver → observe the received voltage and pick the most likely signal (s_0 or s_1).

At the receiver, we will have two voltages that follow Gaussian PDFs. More formally, they follow **Conditional PDFs**:

$$f_y(y | s_0) = \frac{1}{\sqrt{2\pi\sigma_n^2}} e^{-\frac{(y+V)^2}{2\sigma_n^2}}$$

$$f_y(y | s_1) = \frac{1}{\sqrt{2\pi\sigma_n^2}} e^{-\frac{(y-V)^2}{2\sigma_n^2}}$$

The first is the PDF of the Received Voltage **GIVEN THAT** signal s_0 was transmitted. The second is the PDF of the Received Voltage **GIVEN THAT** signal s_1 was transmitted.

Note That: We have implicitly assumed that the two signals are equally probable.

What I want to do here is maximize the probability of choosing the correct signal.

Under the conditions that signals are equally probable, our decision threshold is 0V, and the error probability is given by:

$$P_e = \Pr(s_0) \int_{R_1} f_y(y | s_0) + \Pr(s_1) \int_{R_0} f_y(y | s_1)$$

$$P_e = (0.5) \int_{R_1} f_y(y | s_0) + (0.5) \int_{R_0} f_y(y | s_1)$$

$$P_e = \int_{R_1} f_y(y | s_0)$$

$$P_e = \int_0^{\infty} \frac{1}{\sqrt{2\pi\sigma_n^2}} e^{-\frac{(y+V)^2}{2\sigma_n^2}} dy$$

$$P_e = Q\left(\sqrt{\frac{V^2}{N_0 f_m}}\right)$$

Where: $Q(u) = \int_u^{\infty} \frac{1}{\sqrt{2\pi}} \exp(-x^2/2) dx$

Assume: Both signals have equal energy and equal time duration, and the baseband data has NRZ Signaling.

In that case, the two energies are the same, and $f_m = R_b = \frac{1}{T_b}$

$$\text{Thus: } P_e = Q\left(\sqrt{\frac{V^2}{N_0 f_m}}\right) = Q\left(\sqrt{\frac{E_b}{T_b} \frac{1}{N_0 f_m}}\right) = Q\left(\sqrt{\frac{E_b}{N_0}}\right)$$

But the ML Receiver is really the worst of the three (we can prove that mathematically, but it's easy to think about it empirically).

What I really want to do is find a way to extract the signal from the noise. It's similar to having a conversation with someone in a noisy room. Your brain has the ability to extract someone's voice from the rest of the crowd.

The Correlation Receiver

Consider this: Create a template waveform for a logic 1 and logic 0. Take the incoming bit and correlate it with the template signal: multiply and integrate.

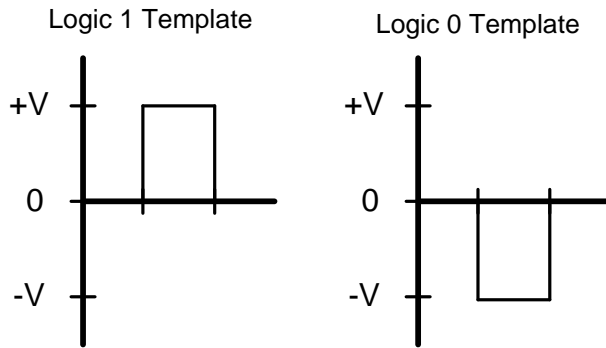

What happens on the output of the integrator (abbreviated derivation in Appendix C):

$$\hat{s}_o(T) = \int_0^T (s(t) + n(t))s(t) dt$$

$$\hat{s}_o(T) = \int_0^T s^2(t) dt + \int_0^T s(t)n(t) dt$$

For a digital signal over one bit period, we know that the value of the signal is going to be constant, thus:

$$\hat{s}_o(T) = \int_0^T (V)^2 dt + \int_0^T (V)n(t) dt$$

$$\hat{s}_o(T) = V^2T + \text{Random Number}$$

Notice: The first term is just a number which will be proportional to the amplitude of our digital bit. The second term is a random “add on” which represents the time integrated noise added to the signal.

We can make the same argument for a binary 0 (-V) volts, with a similar correlator. So we can put both of these together in the following manner:

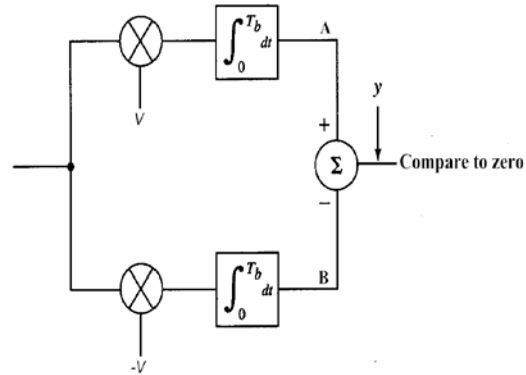

Block Diagram (Figure 2.66c)

To illustrate how this works, consider the following four cases:

<u>Received Bit</u>	<u>+V Correlator Output</u>	<u>-V Correlator Output</u>
1	V^2T	$-V^2T$
0	$-V^2T$	V^2T

So we could conclude that all we need to do is compare the two correlator outputs and always pick the largest. We can further simplify by only correlating with a single template (2.66d):

<u>Received Bit</u>	<u>+V Correlator Output</u>
1	V^2T
0	$-V^2T$

What we observe is that our decision threshold is now 0. **Caution:** That assumes my bits are equally probable and that errors have equal cost.

Note: The simplicity of this system. I just correlate with a template waveform and compare the result to zero. This is really easy to do with any microprocessor, DSP, or digital hardware.

The name of this receiver architecture is the Matched Filter Receiver, and it shows up everywhere in the world of communications, because it is the optimum receiver structure for AWGN channels.

Setting the Detector Threshold

Now, we have a little bit of a problem. The input to our decision circuit is a random variable. Instead of just a number, we have a deterministic part (the V^2T) and a random part (the random noise).

In general, we assume that noise added to our system is AWGN, so that it follows a Gaussian PDF. That means that the input to our detector is a Gaussian RV (which is nice). What happens now is that the input to my detector can be modeled as a pair of PDF's (see powerpoint slide).

In order to make a determination on which bit I choose, I have to know two things:

- The probability of sending each bit
- The cost of making an error

Under the conditions where the two bits are equally probable and errors are equal cost (which is what happens in digital communication systems), the decision threshold is exactly in between. Does this prevent errors? No, but it does minimize the total cost of making errors.

I can easily expand this argument to multi-level signaling. In that case, I'm going to be looking at signal regions. Notice that as soon as I go to multi-level signaling on a single axis, my region sizes are no longer equal.

The Maximum A Posteriori Receiver (Matched Filter Receiver)

Consider this: Create a template waveform for a logic 1 and logic 0. Take the incoming bit and correlate it with the template signal: multiply and integrate.

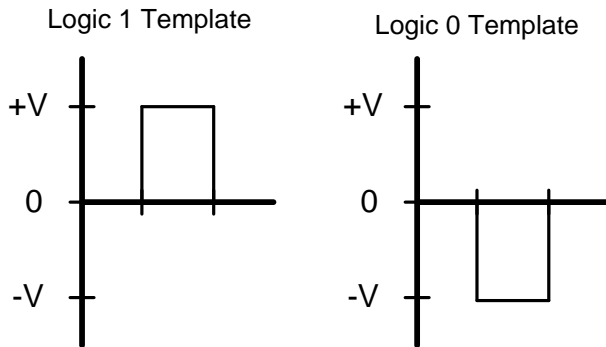

What happens on the output of the integrator:

$$\hat{s}_o(T) = \int_0^T (s(t) + n(t))s(t) dt$$

$$\hat{s}_o(T) = \int_0^T s^2(t) dt + \int_0^T s(t)n(t) dt$$

For a digital signal over one bit period, we know that the value of the signal is going to be constant, thus:

$$\hat{s}_o(T) = \int_0^T (V)^2 dt + \int_0^T (V)n(t) dt$$

$$\hat{s}_o(T) = V^2T + \text{Random Number}$$

Notice: The first term is just a number which will be proportional to the amplitude of our digital bit. The second term is a random “add on” which represents the time integrated noise added to the signal.

We can make the same argument for a binary 0 (-V) volts, with a similar correlator. So we can put both of these together in the following manner:

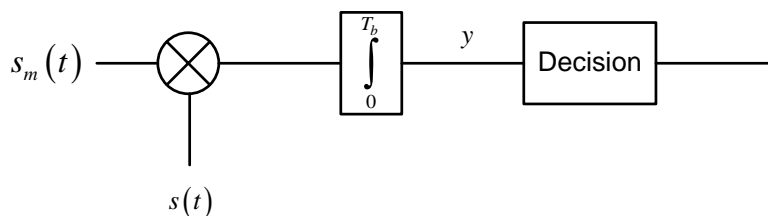

The name of this receiver architecture is the Matched Filter Receiver, and it shows up everywhere in the world of communications, because it is the optimum receiver structure for AWGN channels

To illustrate how this works, consider the following cases:

<u>Received Bit</u>	<u>Correlator Output</u>
1	V^2T
0	$-V^2T$

So we could conclude that all we need to do is compare the two correlator outputs. What we observe is that our decision threshold is $0V$.

Note: The simplicity of this system. I just correlate with a template waveform and compare the result to zero. This is really easy to do with any microprocessor, DSP, or digital hardware.

Note 2: In order to make a determination on which bit I choose, I have to know two things:

- The probability of sending each bit
- The cost of making an error

Under the conditions where the two bits are equally probable and errors are equal cost (which is what happens in digital communication systems), the decision threshold is exactly in between. Does this prevent errors? No, but it does minimize the total cost of making errors.

I can easily expand this argument to multi-level signaling. In that case, I'm going to be looking at signal regions. Notice that as soon as I go to multi-level signaling on a single axis, my region sizes are no longer equal.

Performance of the Matched Filter Receiver

Note: $r(t) = s(t) + n(t)$

At the receiver, we will have two voltages that follow Gaussian PDFs. More formally, they follow **Contional PDFs**:

$$f_y(y | s_0) = \frac{1}{\sqrt{2\pi\sigma_n^2}} e^{-\frac{(y+V)^2}{2\sigma_n^2}}$$

$$f_y(y | s_1) = \frac{1}{\sqrt{2\pi\sigma_n^2}} e^{-\frac{(y-V)^2}{2\sigma_n^2}}$$

The first is the PDF of the Received Voltage **GIVEN THAT** signal s_0 was transmitted. The second is the PDF of the Received Voltage **GIVEN THAT** signal s_1 was transmitted.

What I want to do here is minimize the cost of making an error. (NB: A Threshold receiver will maximize the probability of choosing the correct signal) To do that, I want to maximize the *a posteriori* probability of choosing the correct signal **GIVEN THAT** we know something about the transmitted signal. Mathematically, we want to select the signal that satisfies:

$$\Pr(s_i | r) \geq \Pr(s_j | r) \text{ for all } i \neq j$$

or equivalently,

$$f(r | s_i) \Pr(s_i) \geq f(r | s_j) \Pr(s_j) \text{ for all } i \neq j$$

Where $f(r | s_i)$ is the conditional PDF of the received voltage, same as in the Maximum Likelihood receiver. The difference here is that we now know something about the *a priori* probabilities of transmitting s_0 and s_1 . We also know that we've correlated with the received signal, and we've created a new signal y from our observed received signal $r(t) = s(t) + n(t)$.

How do we get there? The detailed derivation is reserved for a digital communications class, but let's cut to the chase:

Consider a general correlator demodulator where the received signal is correlated with a function $h(t)$

$$\begin{aligned} y &= \int_0^T r(t)h(t)dt \\ &= \int_0^T (s(t) + n(t))h(t)dt \\ &= \int_0^T s(t)h(t)dt + \int_0^T n(t)h(t)dt \end{aligned}$$

If we look closer at this expression, here's what we can observe:

Desired Component $y = \int_0^T s(t)h(t)dt + \int_0^T n(t)h(t)dt$ Noise Component

$$SNR = \frac{\left[\int_0^T s(t)h(t)dt \right]^2}{E \left[\left(\int_0^T n(t)h(t)dt \right)^2 \right]}$$

Avg Noise Power

Where $E[\bullet]$ is the expectation operator.

We can look closer at the noise power term:

$$E \left\{ \left[\int_0^T n(t)h(t)dt \right]^2 \right\} = \int_0^T \int_0^T E \{ n(t)n(\tau) \} h(t)h(\tau)dt d\tau$$

Note That: You can't square an integral by squaring all the terms inside the integral. You have to write it as the product of two integrals.

$$\begin{aligned} E \left\{ \left[\int_0^T n(t)h(t)dt \right]^2 \right\} &= \frac{N_o}{2} \int_0^T \int_0^T \delta(t-\tau)h(t)h(\tau)dt d\tau \\ &= \frac{N_o}{2} \int_0^T h^2(t)dt \end{aligned}$$

From the Cauchy-Schwarz Inequality we can write:

$$SNR = \frac{\left[\int_0^T s(t)h(t)dt \right]^2}{\frac{N_o}{2} \int_0^T h^2(t)dt} \leq \frac{\int_0^T s^2(t)dt \int_0^T h^2(t)dt}{\frac{N_o}{2} \int_0^T h^2(t)dt}$$

Where the equality is obtained when $h(t) = s(t)$. Thus, the demodulator that maximizes SNR at the output is the correlator demodulator where $h(t) = s(t)$.

Key Observations

- The demodulator which correlates with the symbol waveform or which uses a matched filter matched to the symbol waveform maximizes SNR.
- The Matched Filter demodulator is optimal in that it provides the max SNR (as measured at the output of the Matched Filter). The detector is optimal in that given it minimizes probability of error.

The SNR at the output of a Matched Filter Receiver can be obtained via:

$$\begin{aligned} SNR &= \frac{\int_0^T s^2(t)dt \int_0^T s^2(t)dt}{\frac{N_o}{2} \int_0^T s^2(t)dt} \\ &= \frac{\int_0^T s^2(t)dt}{\frac{N_o}{2}} \\ &= \frac{2E_b}{N_o} \end{aligned}$$

Thus, the performance of the system is given by:

$$P_e = Q\left(\sqrt{\frac{2E_b}{N_0}}\right) \text{ which is 3 dB better than the ML receiver.}$$